

ALTON

Design Guide

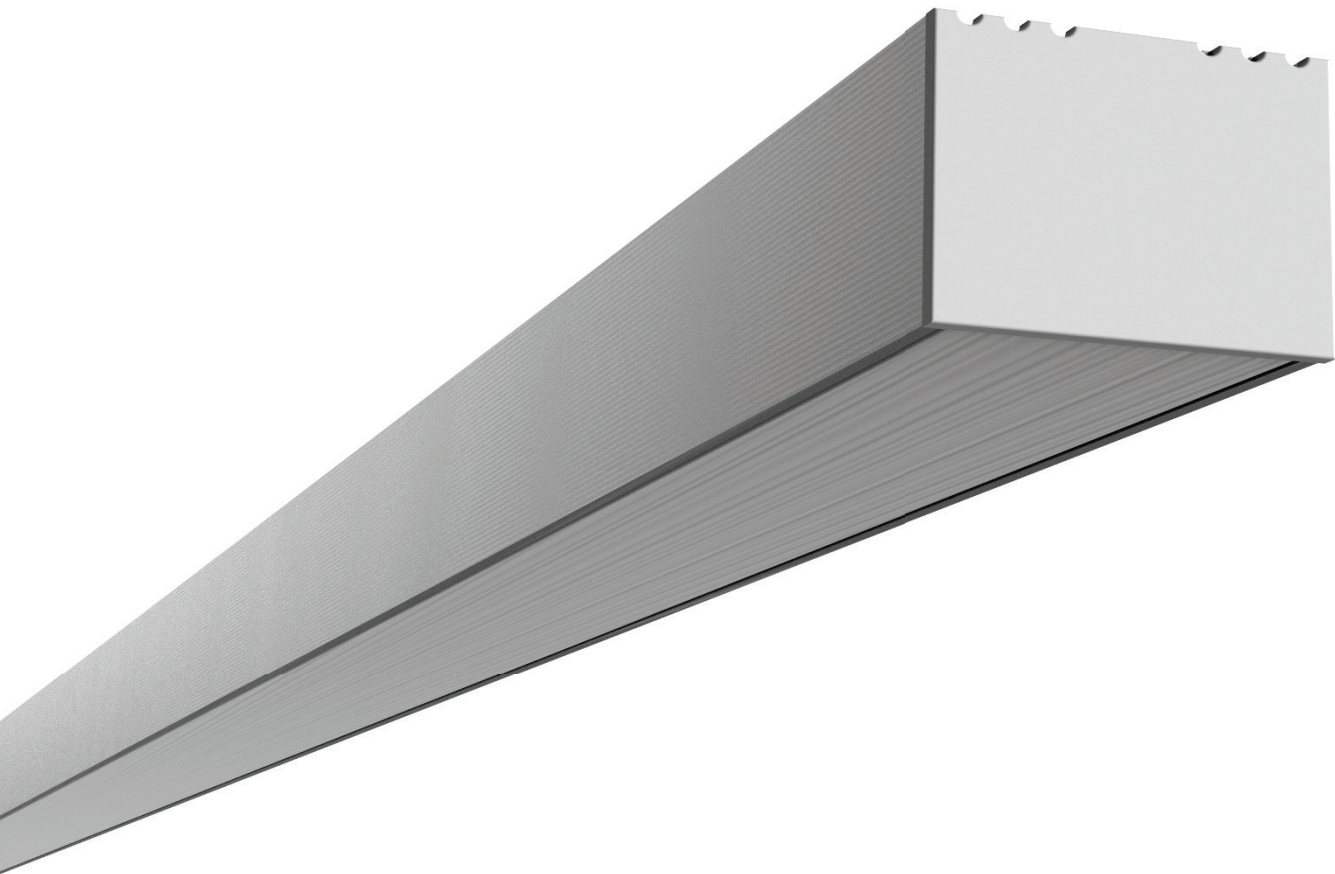

Profile & Dimensions

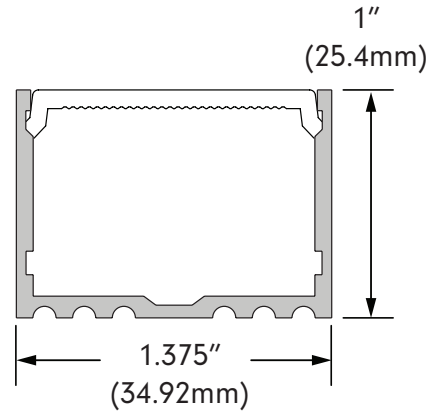
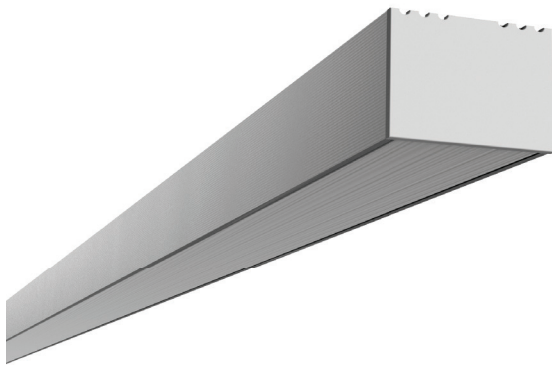

Available TivoTape Options - Indoor

DEFINE
SB
HO
LB

ELITE
SB
HO
VHO

ELITE+
Plus
Pro
Vision
Flow

FUSE24
RGB
RGB+W
RGB+W+W
DW
Pixle24 RGB
Pixle24 RGBW

FUSE12
PiXEL12 RGB

Available TivoTape Options - Outdoor

DEFINE
SB
HO
LB

FUSE24
RGB

FUSE12
PiXEL12 RGB

Ordering Information

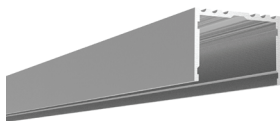

ALTN-CHAN-SLV-6.5
Anodized Aluminum Extrusion,
available in 6.5' lengths



ALTN-LNS-XXX-6.5
XXX = OPAL (Opal), **CLR**
(Clear), **DIF** (Diffused)
lens, length 6.5'



ALTN-EC-01
Solid End Cap



ALTN-EC-02
Powerfeed End Cap

Photometrics (based on 30K HO ELITE)

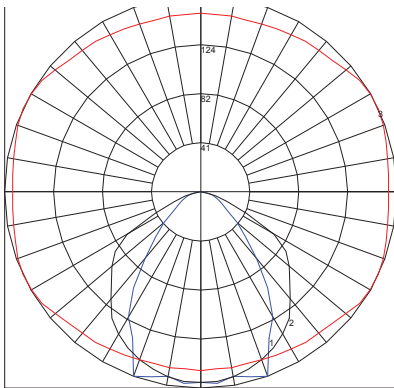

ALTON WITH CLEAR LENS
 Lumens per foot: 332.86
 Watts per foot: 4
 CRI : 94.8
 Peak Candela: 164.97

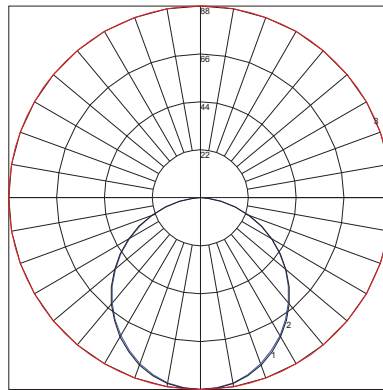

ALTON WITH DIFFUSED LENS
 Lumens per foot: 248.85
 Watts per foot: 4
 CRI : 95.7
 Peak Candela: 88.38

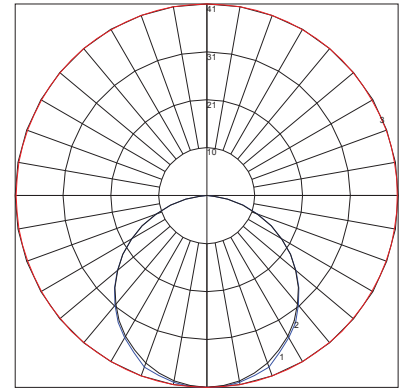

ALTON WITH OPAL LENS
 Lumens per foot: 120.31
 Watts per foot: 4
 CRI : 98.1
 Peak Candela: 41.24

Diode Visibility

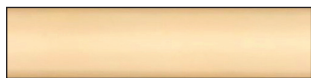

Opal lens



Clear lens

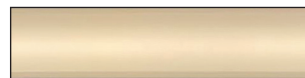

Diffused lens

